



Honeyville Cyclones



Sizes Ranging from 575 CFM to 57,000 CFM



Centrifugal Cyclone Collectors



FEATURING

- ❑ Twenty-six Standard Models for a Large Range of Applications.
- ❑ All Welded Carbon Steel, Butt Seam Construction for Longer Wear. Three Gauge Thickness Classification, Standard Duty, Heavy Duty, and Extra Heavy Duty.
- ❑ Optional Materials, G-90 Galvanized, 304 or 316 Stainless Steel, AR Steel.
- ❑ Manifold Outlet on Vent for Air Return to Filter Bag House or Optional Adjustable Atmospheric Weather Cap.
- ❑ 15° deg. Conical Roof on All Models over 30" dia. for Greater Vent Tube Stability.
- ❑ Safety Ring Mounted at Roof Edge for Attachment of Installers P.P.E. (Personal Protection Equipment) while Installing Pipe, Manifold or Vent Cap.
- ❑ Finish Coated Exterior Surface, consists of Base Primer Coat and Alkyd Industrial Enamel Finish.
- ❑ Optional Cone Access Door, 14" Dia. Bolt-on, Laminated Panel is Flush with Inside Surface.

Sawdust or Wood Shavings, Wood Grinder Chips, Paper Pulp, Paper or Cardboard Scraps and Dust, Grain Processing Dust, Ground Feed, Rice Processing Dust, Minerals, Flyash, Seed Processing Dust, Plastic Pellets, PVC Pellets, Rubber Dust, Foundry Sand, Clay Dust, Textile Processing Dust, Animal Feed Pellet Processing,

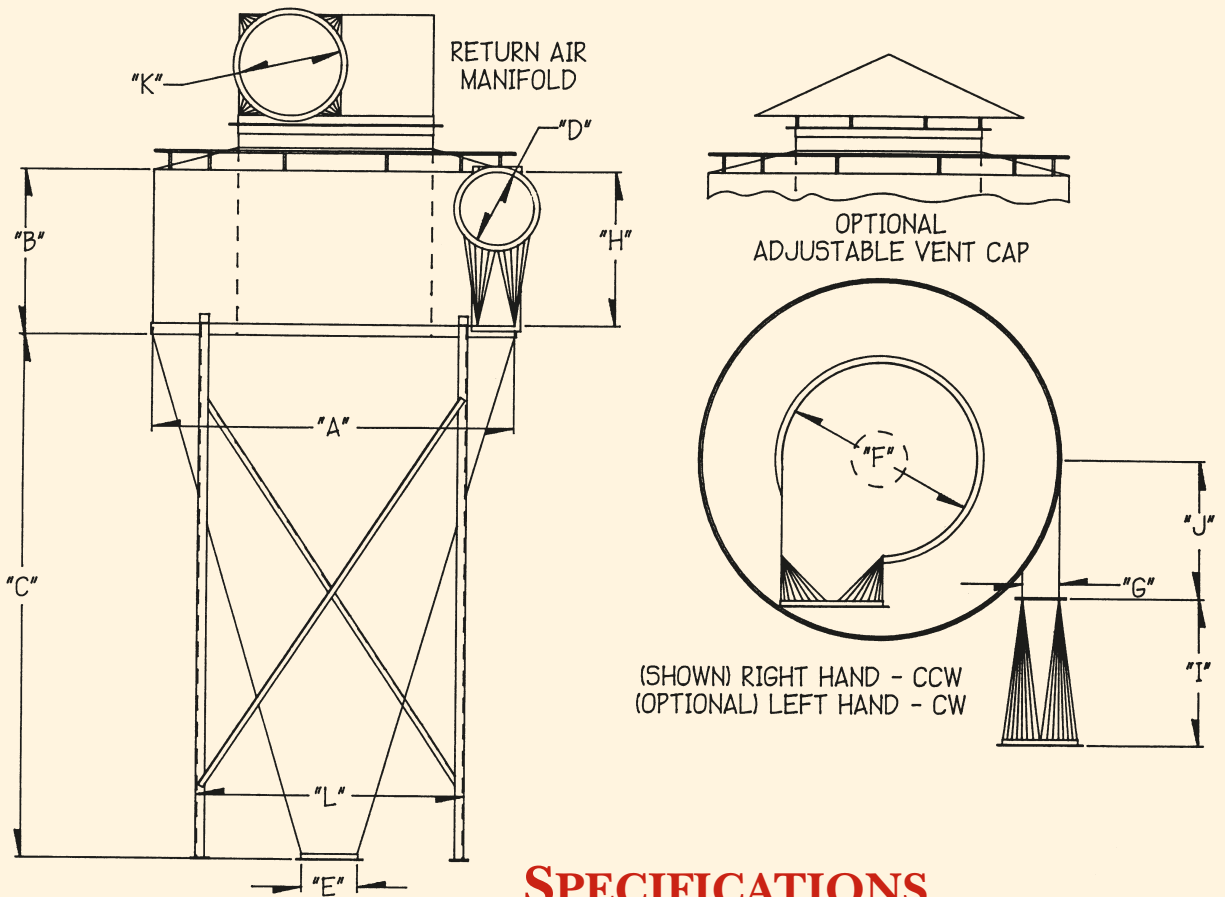

SPECIFICATIONS

Model	A	B	C	D	E	F	B ga	C ga	G	H	I	J	K	L	CFM RANGE	WEIGHT
MH20-HE	20"	18"	3'6"	6"	7"	10"	12	14	4"	11"	11"	12"	9"	16½"	550-1300	170#
MH24-HE	24	22	4'1"	7	7	12	12	14	4½	12½	12½	13½	10	19½	675-1600	200
MH30-HE	30	26	4'10"	8	10	15	12	14	5	14	14	15¾	11	23½	850-2000	300
MH36-HE	36	30	6'2"	9	10	18	12	14	5½	15½	15½	17	12	28½	1050-2500	420
MH42-HE	42	36	7'7"	10	10	21	12	14	6	17	17	18¾	14	32¾	1470-3500	575
MH18	18	10	2'4"	5	6	10	14	16	2½	10	10	7½	7	15	575-800	120
MH24	24	12	3'2"	6	8	12	14	14	3	12	12	10	8	19½	900-1300	150
MH30	30	16	4'0"	8	8	16	14	14	4	16	16	12¼	11	23½	1200-1700	200
MH36	36	20	5'2"	9	10	21	14	14	4½	18	18	15	12	28½	1600-2250	250
MH42	42	24	6'0"	10	10	23	14	14	5	20	20	17¼	14	32¾	2100-2900	320
MH48	48	30	7'0"	11	10	26	12	14	5½	22	22	19¼	15	37	2700-3500	490
MH54	54	30	8'0"	12	10	30	12	14	6	24	24	21½	16	41¼	3200-4500	575
MH60	60	36	8'6"	13	10	33	12	14	6½	26	26	24¾	17	45½	4200-5500	720
MH66	66	36	9'2"	14	10	36	12	14	7	28	28	26¾	18	49¾	5200-6500	820
MH72	72	36	9'6"	15	12	38	12	14	7½	30	30	27¼	20	54¾	5800-7500	900
MH78	78	36	9'9"	16	12	42	12	14	8	32	32	30¼	22	59	6900-8800	1030
MH84	84	36	10'6"	18	14	46	12	14	9	32	36	33	24	63¾	8000-10000	1140
MH90	90	42	11'3"	19	14	48	12	12	9½	32	38	35¼	26	68¾	9000-12250	1650
MH96	96	42	12'0"	20	16	54	12	12	10	38	40	37¼	27	73	10000-14500	1870
MH108	108	48	13'6"	22	16	60	12	12	11	38	44	41¾	30	82	13000-18750	2260
MH120	120	60	15'0"	25	16	66	10	10	12½	50	50	46¾	34	90½	16000-23000	3670
MH132	132	66	16'5"	28	16	72	10	10	14	56	56	51¾	38	99½	21250-28875	4660
MH144	144	72	18'0"	32	16	80	10	10	16	64	64	57¼	44	109	26500-34750	5600
MH156	156	78	19'6"	34	20	84	10	10	17	66	66	61¾	46	119	31500-41175	6500
MH168	168	84	21'0"	36	24	90	7	7	18	66	66	66	48	143	36500-47600	9350
MH180	180	90	22'5"	40	24	100	7	7	20	72	72	71½	54	151	44000-57500	10800

**High
Efficiency**

**High
Volume**

Collectors



FEATURING

- ❑ Ten Models for Applications where Maximum Efficiency is required.
- ❑ Scientifically Designed for Maximum Efficiency. Low Velocity Tangential Vent Outlet for Less Air Turbulence.
- ❑ Involute Designed. 135° deg. Scroll Inlet moves Material past Interior Conical Baffle for Better Material and Air Separation.
- ❑ A Tall Body and Steep Cone Design assures a Faster Drop of Material to Cone Outlet.
- ❑ Body and Cone Constructed of Heavy Gauge, Welded, Carbon Steel. Flanged Mid-section to Bolt Together at Job Site. Making it Easy to Handle and Install.
- ❑ Optional Material G-90 Galvanized Steel, 304 or 316 Stainless Steel, AR Steel.
- ❑ Finish Coated Exterior Surface, consists of Base Primer Coat and Alkyd Industrial Enamel Finish.
- ❑ Optional Cone Access Door, 14" Dia. Bolt-on, Laminated Panel is Flush with Inside Surface.

Wood Flour, Soybean Meal, Gypsum, Grain Processing Flour such as: Corn, Beans, Wheat, Rye, Rice, Spelts, Barley and Oats, Hay Processing Dust, Bonemeal, Salt, Cottonseed, Limestone Dust, Minerals, Flyash, Powder Coatings, Graphite, Silica Gel, PVC Powder, Charcoal Dust, Cement Dust, Peanut Dust, Plastic Resins,

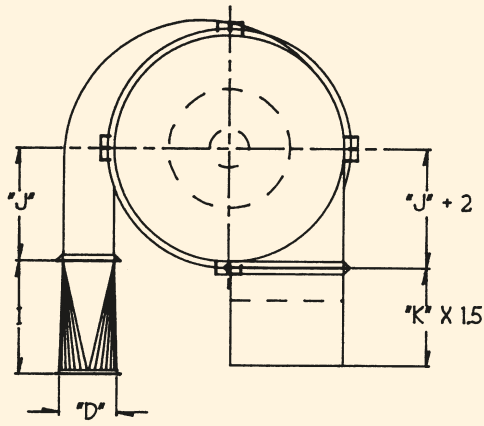

OPTIONAL
OUTLET
TRANSITION



OUTLET HOOD

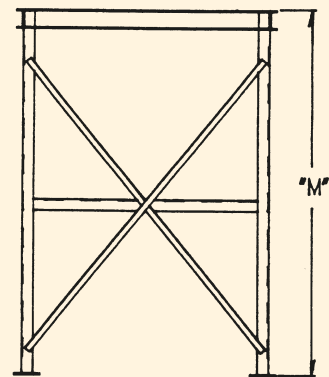
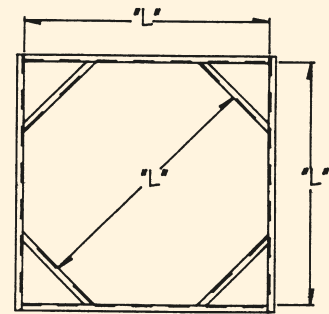
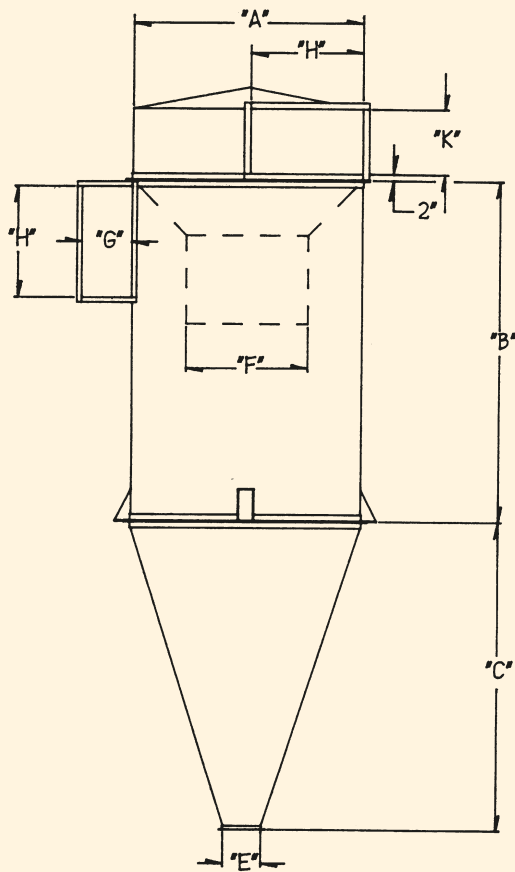
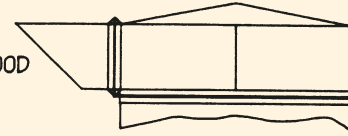

SPECIFICATIONS

Model	A	B	C	D	E	F	B ga	C ga	G	H	I	J	K	L	M	CFM	WEIGHT
MH36HE/HV	36"	54"	4'2"	12"	10"	19"	12	14	8"	17½"	24"	18"	10¼"	45"	5'2"	2200-2800	500
MH48HE/HV	48	72	5'6"	14	10	25¼	12	14	10½	23½	28	24	13¾	53	6'6"	3600-4900	825
MH60HE/HV	60	90	6'10"	16	10	31½	12	14	13¼	29¼	32	30	17¼	65	8'4"	6100-7200	1500
MH72HE/HV	72	108	8'2"	18	12	38	12	14	15¾	35¼	36	36	20¾	77	9'8"	8500-10600	2050
MH84HE/HV	84	122	9'4"	20	12	44	12	14	18½	41	40	42	24¼	89	11'4"	11700-14800	2500
MH96HE/HV	96	135	10'8"	22	16	50½	10	12	21	47	44	48	27¾	101	12'8"	15700-19600	4100
MH108HE/HV	108	146	12'0"	24	16	57	10	12	23¾	52¾	48	54	31¼	113	14'6"	19800-24300	4800
MH120HE/HV	120	156	13'6"	28	16	63	10	12	26½	58¾	56	60	34½	125	16'0"	24300-29800	5650
MH132HE/HV	132	165	15'0"	32	16	70	7	10	29	64½	64	66	38	137	18'0"	28800-35200	8900
MH144HE/HV	144	172	16'4"	36	16	76	7	10	31½	70½	72	72	41½	149	19'4"	33700-41000	10600

HMI Dust Control Solutions for your Industry

From our specifications you will note that both our Standard Cyclones and HE/HV Models use a long cone design; tests show the longer the cone the more effective separation in the cyclone.

With 36 Models, Honeyville is able to supply cyclones for many applications and for many different industries. Our MH Models are used most often for application in the Milling, Feed Processing, Seed Cleaning, Woodworking, and many other Industrial Dust Collecting Operations.

For application where abrasive material such as Wet Sawdust, Sand, Plastic, Cement Dust, Foundry Dust, or other Metal Dusts are being separated, collectors can be supplied Heavy Duty or Extra Heavy Duty in Hot Rolled Carbon Steel, Galvanized Steel, Stainless Steel and AR Steel for extended wear. With over 46 years experience building cyclone collectors there are few situations we haven't dealt with already. Honeyville offers custom engineering for complete pneumatic systems to your specific needs.

TYPICAL DUST RECOVERY CURVE

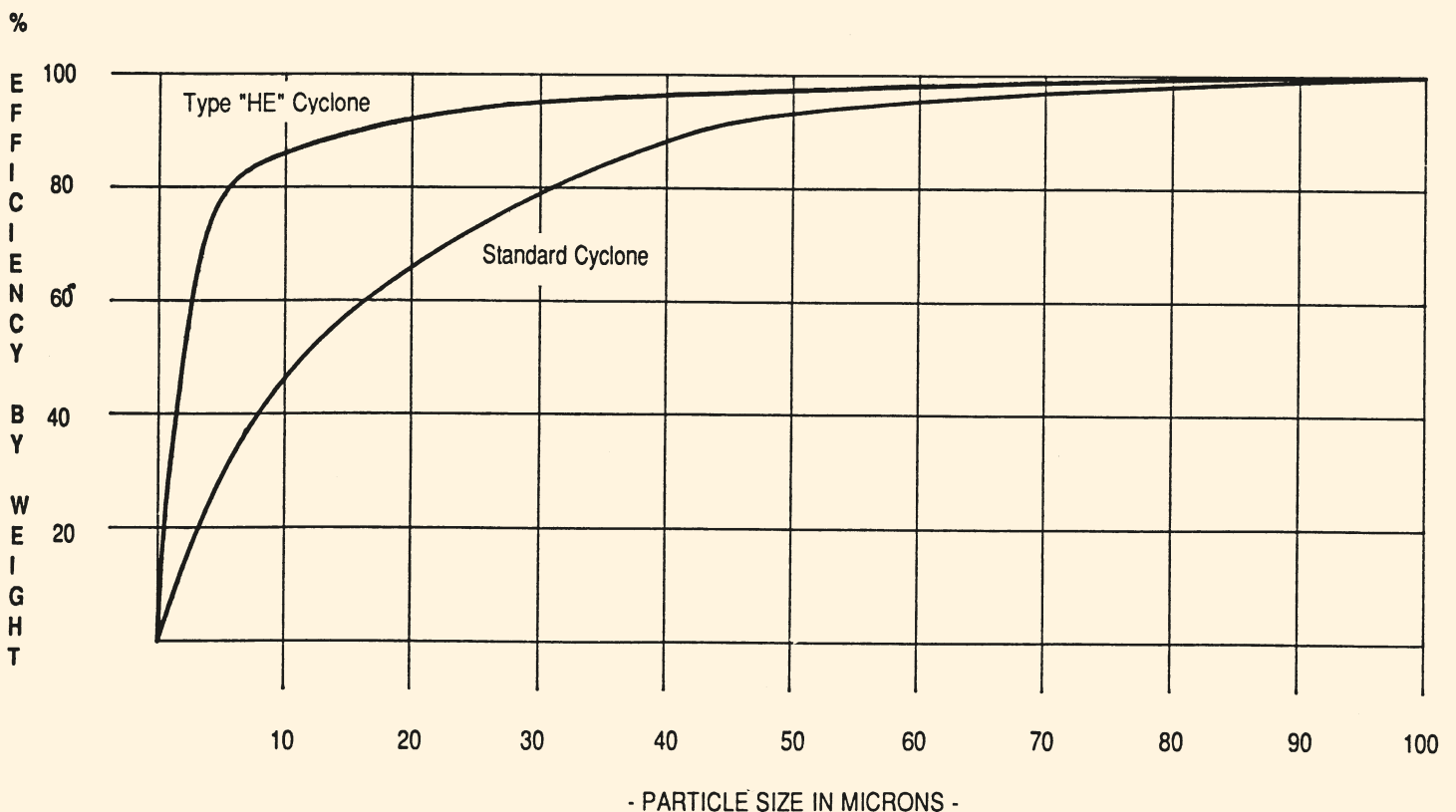

QUALITY BUILT COLLECTORS AT AFFORDABLE PRICES



All welded oversized cyclone being delivered with main fan and relay fan.

15' dia. Cyclone sectioned with flanges for shipping purposes.



Relay cyclone on top of a cement silo for storage. Open top cyclone located in a handle manufacturing plant with no return air filtration.



Relay cyclone on top of a Honeyville Metal welded storage bin with overhead load-out. Cyclone is one component in this complete Honeyville Metal Dust System in a woodworking plant.

Photos show typical systems at woodworking plants.



EFR Cyclone filter combination on a sub-stand with a Lacey Harmer dumpster under for storage.



Two open top cyclones dropping into a common closed loop relay system.

Manufactured by



4200S 900W • Topeka, IN 46571
 Phone (800) 593-8377 • Fax (260) 593-2486
www.honeyvillemetal.com